

Left view  
Scale: 1:8

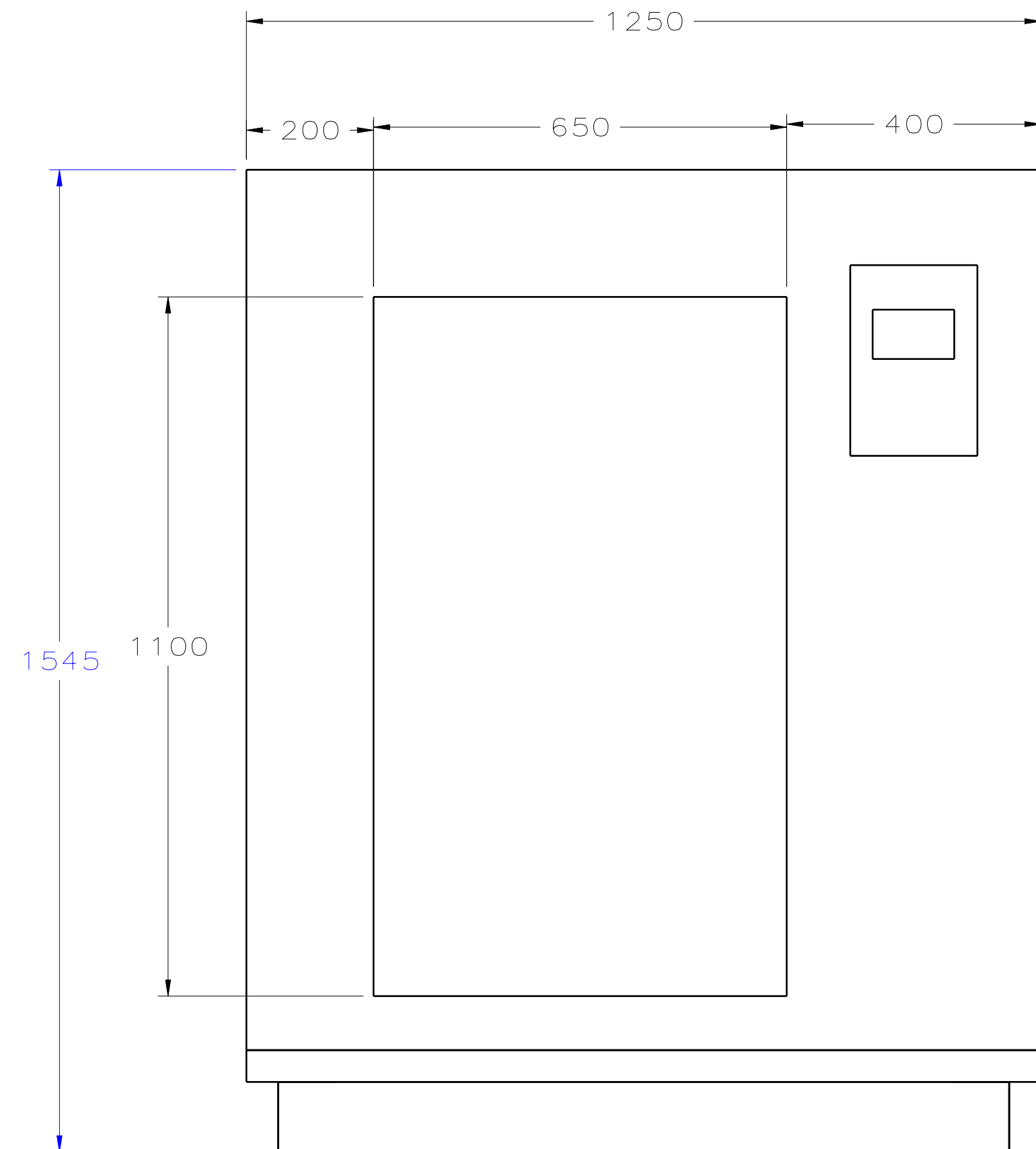

Front view  
Scale: 1:8

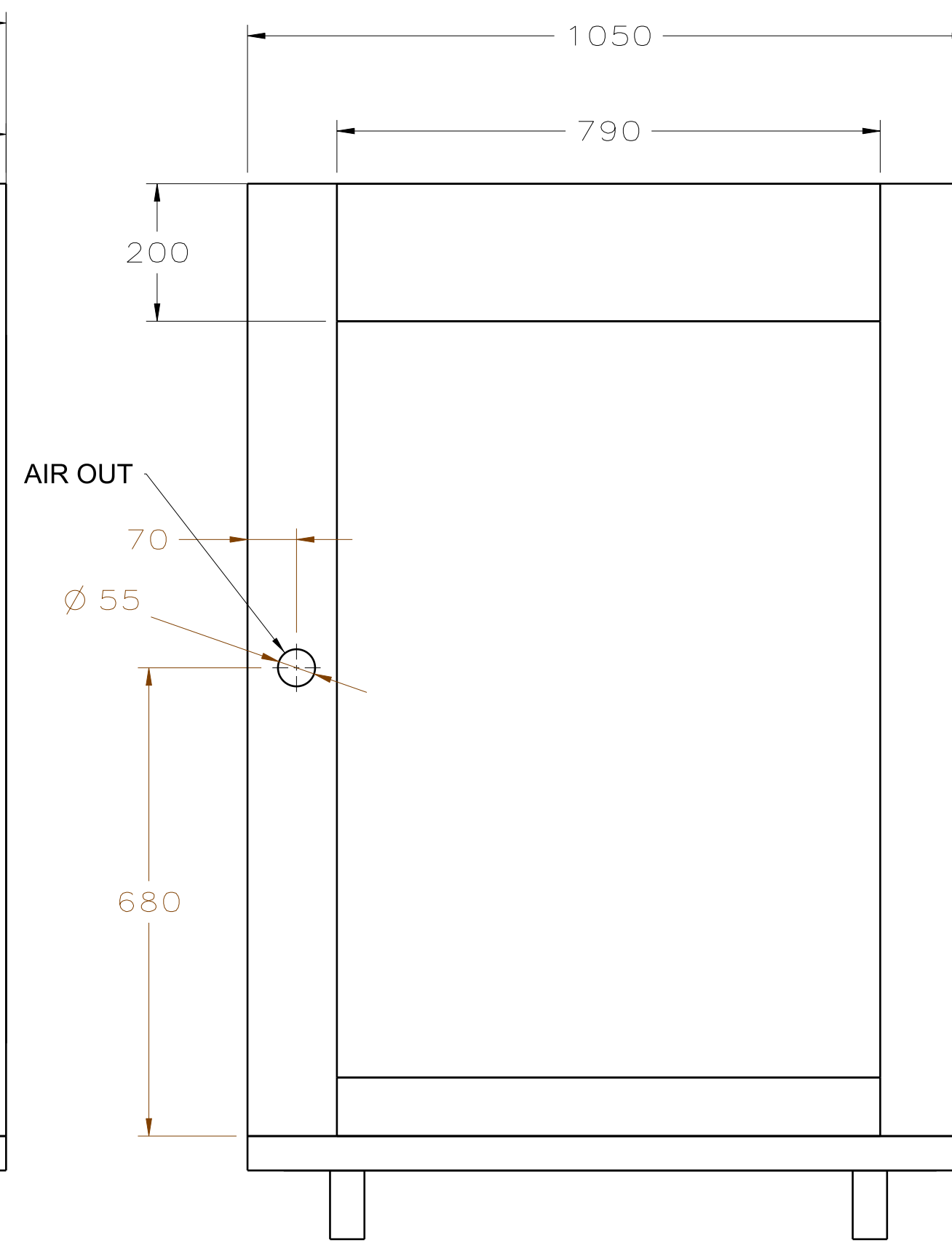

Right view  
Scale: 1:8

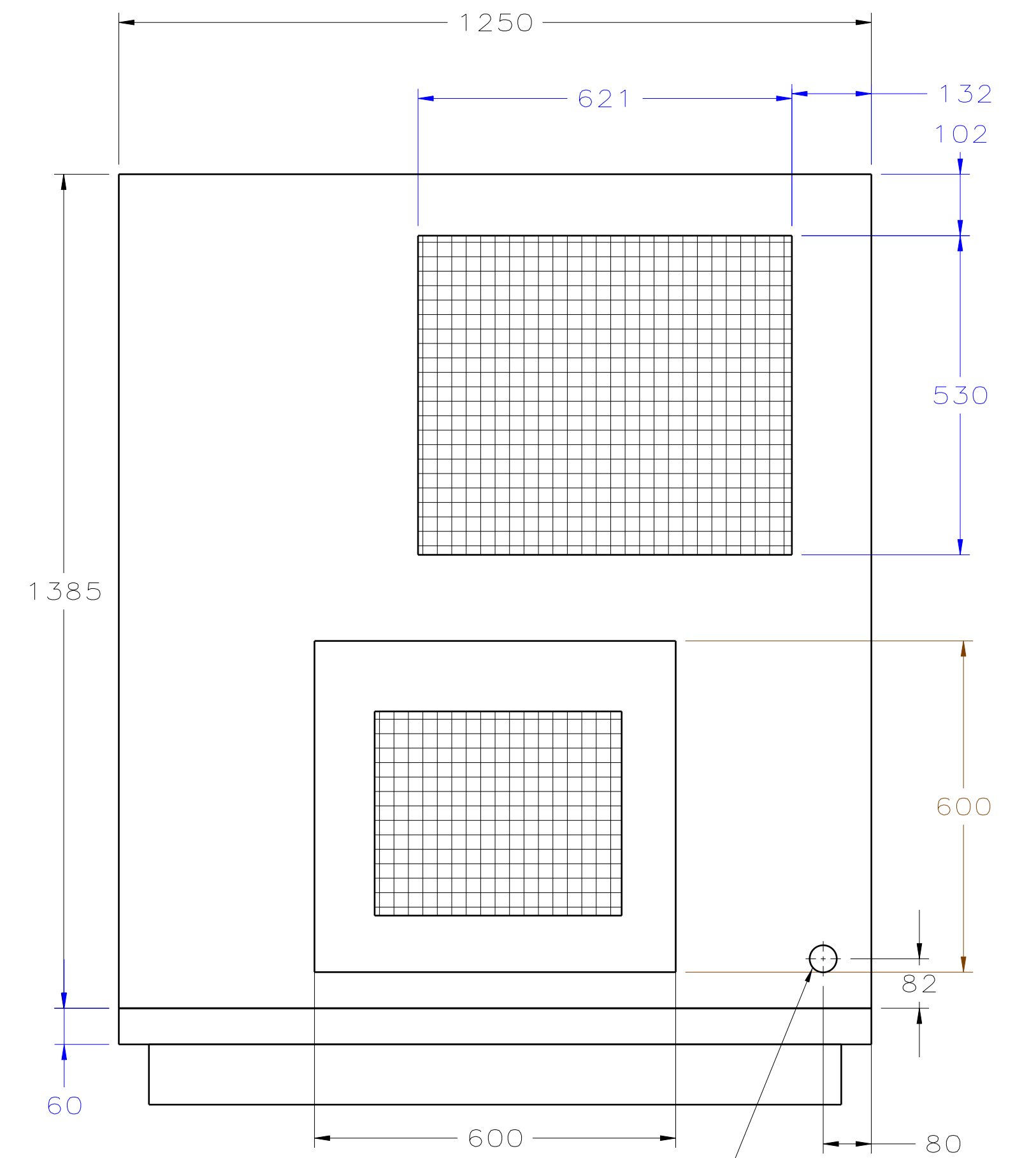

Rear view  
Scale: 1:8

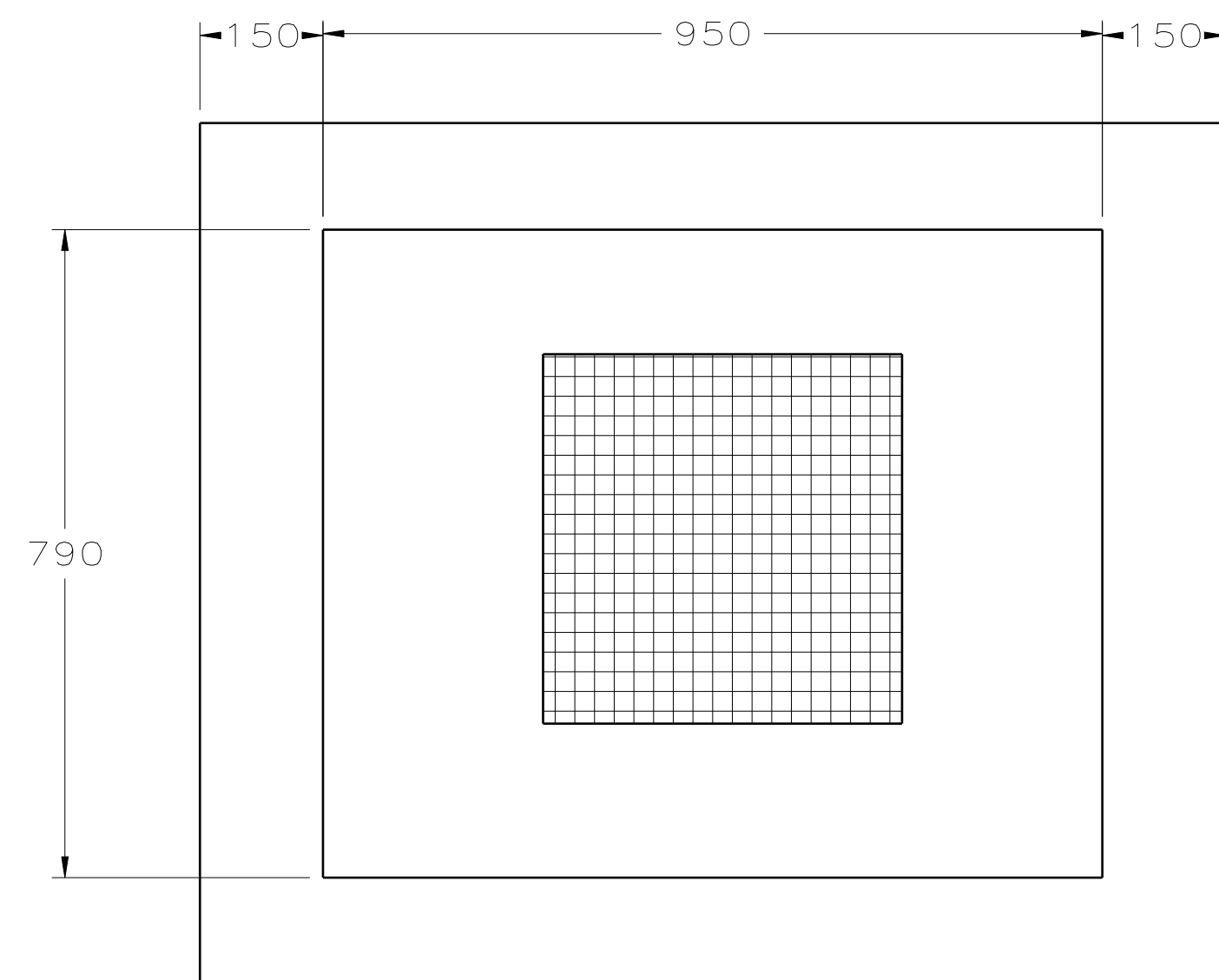

Top view  
Scale: 1:8

NOTES:

CONNECTIONS		
A	COMPRESSED AIR OUTLET	1-1/4" MALE
B	ELECTRICAL ENTRY	40 mm
C	OIL TANK DRAIN	1/2" FEMALE WITH PLUG
D	AIR COOLING FLOW RATE	3.6 m3/min
E	CONDANSATE DRAIN POINT	—
F	WEIGHT	667

25.05.2021

ITEM NO	QTY REQD	CODE IDENT	PART OR IDENTIFYING NO	NOMENCLATURE OR DESCRIPTION	MATERIAL	SPECIFICATION	ZONE
LIST OF MATERIALS OR PARTS LIST							
THIS DRAWING IS THE PROPERTY OF ANKARA HAMAK IND. AND IS TRANSMITTED IN CONFIDENCE. NEITHER RECEIPT NOR POSSESSION CONFERS OR TRANSFERS ANY RIGHT TO REPRODUCE, USE OR DISCLOSE, IN WHOLE OR PART, DATA CONTAINED HEREIN FOR ANY PURPOSE, WITHOUT THE WRITTEN PERMISSION OF ANKARA HAMAK IND.							
UNLESS OTHERWISE SPECIFIED DIMENSIONS ARE IN INCHES TOLERANCES ON				CONTRACT NUMBER			
FRACTIONS		DECIMALS		DATE OF DRAWING			
±	—	.X	±	11 JAN 2007			
ANGLES		.XX ±		DRAFTSMAN		CHECKER	
±	—	.XXX ±	±	V. SAKAL		I. KARAHAN	
				ENGINEER		FUNCTIONAL DESIGN	
				B. OZKAN		CODE IDENT NO.	
				MANUFACTURING		WELDING	
				APPROVED		DRAWING NO.	
				R. ÖKÇÜN		A1 I0-0370-9100	
NEXT ASSY		USED ON		SCALE		UNIT WT ——— LB SHEET OF	
APPLICATION							



**VSD 30-37 COMPRESSOR**  
**DIMENSIONS**