

Right view
Scale: 1:8

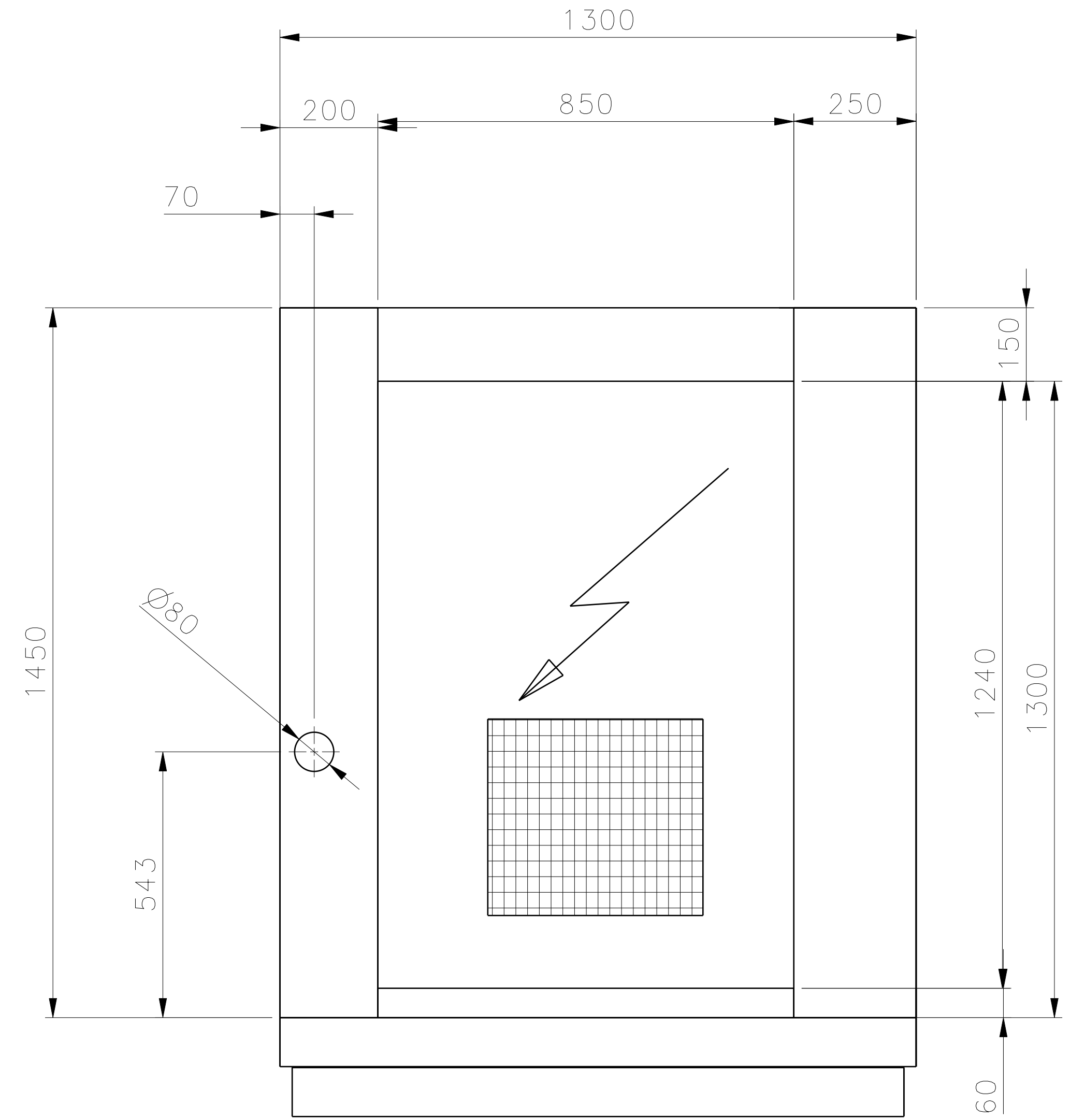

Left view
Scale: 1:8

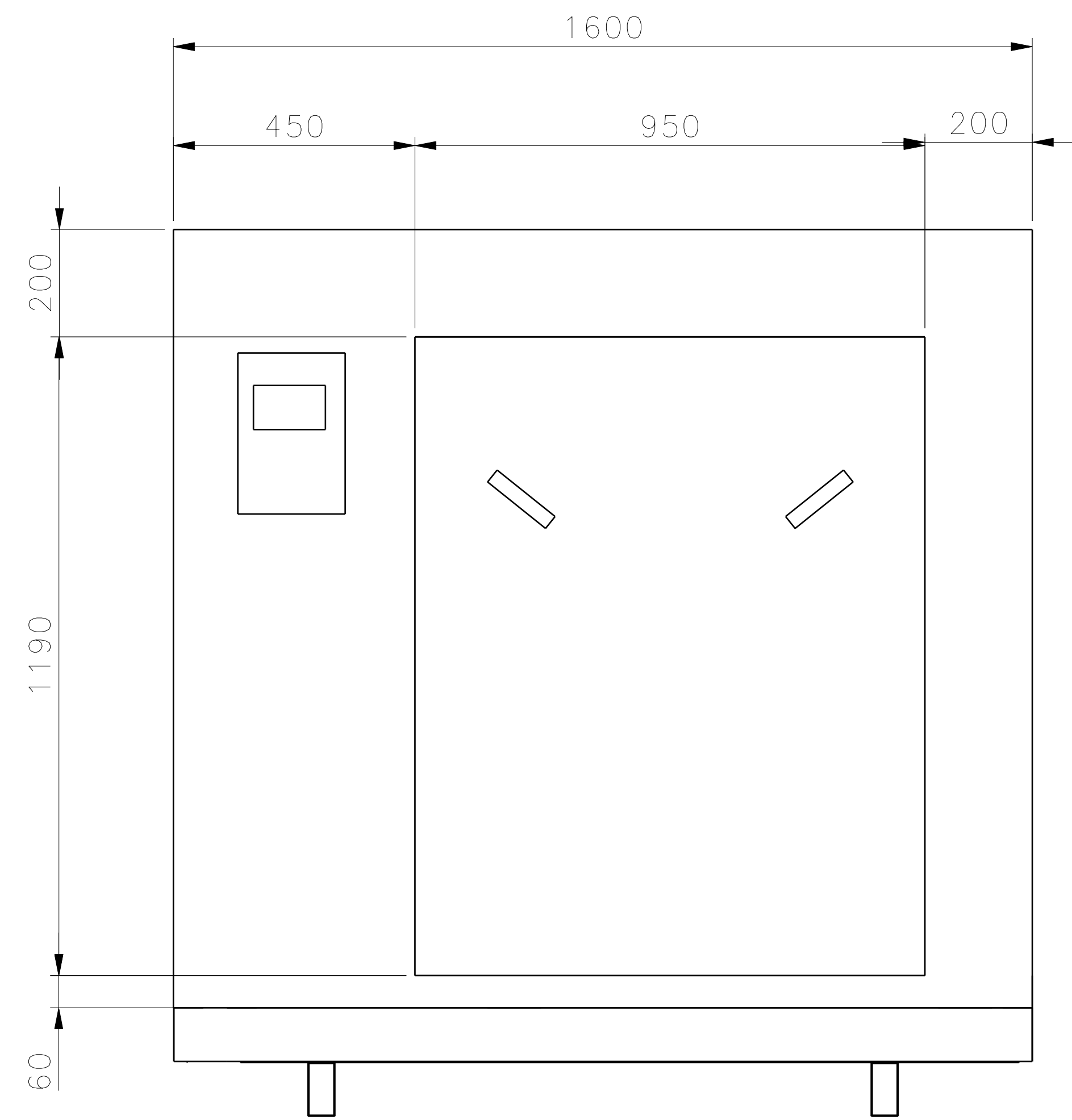
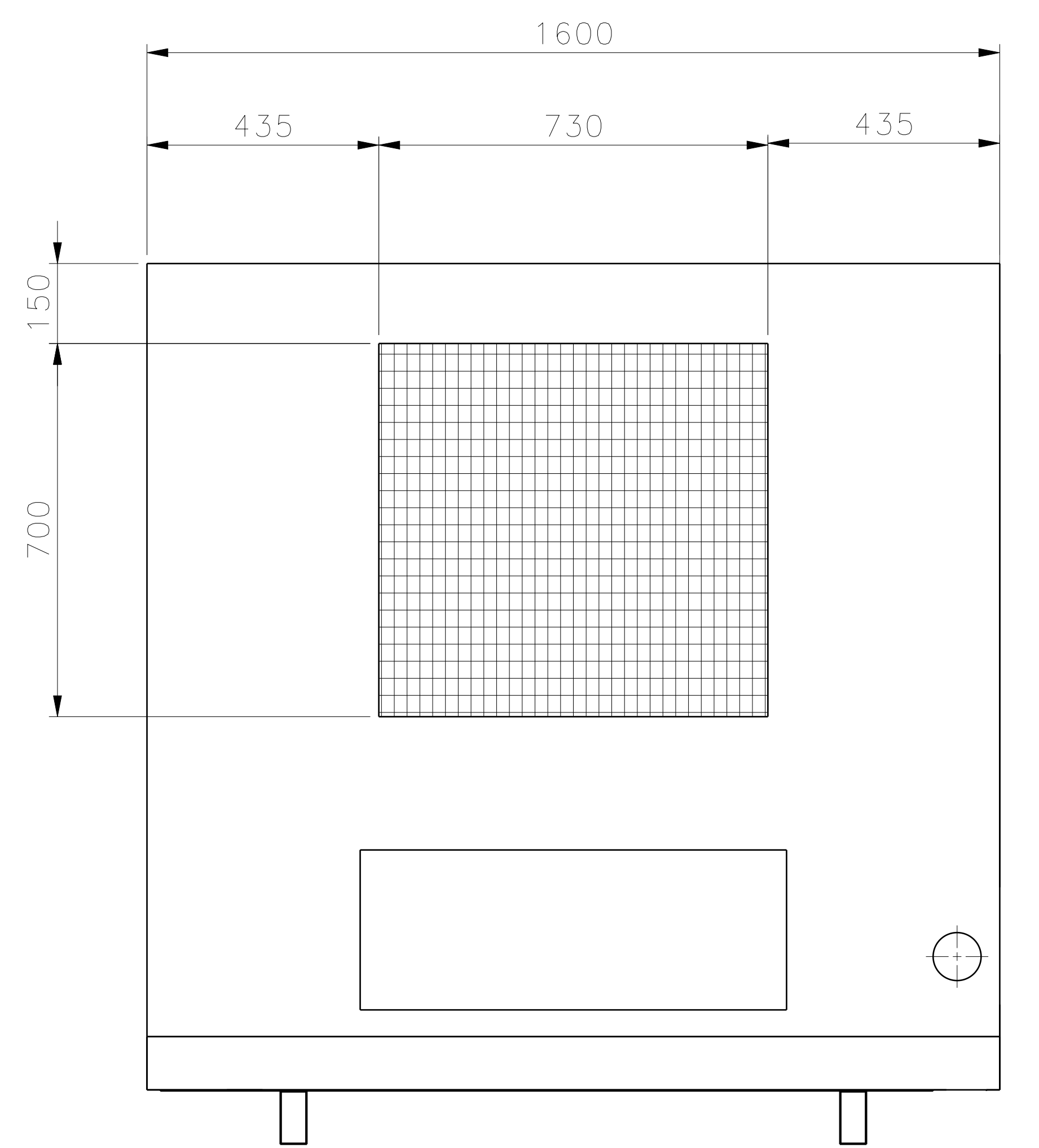

Rear view
Scale: 1:8

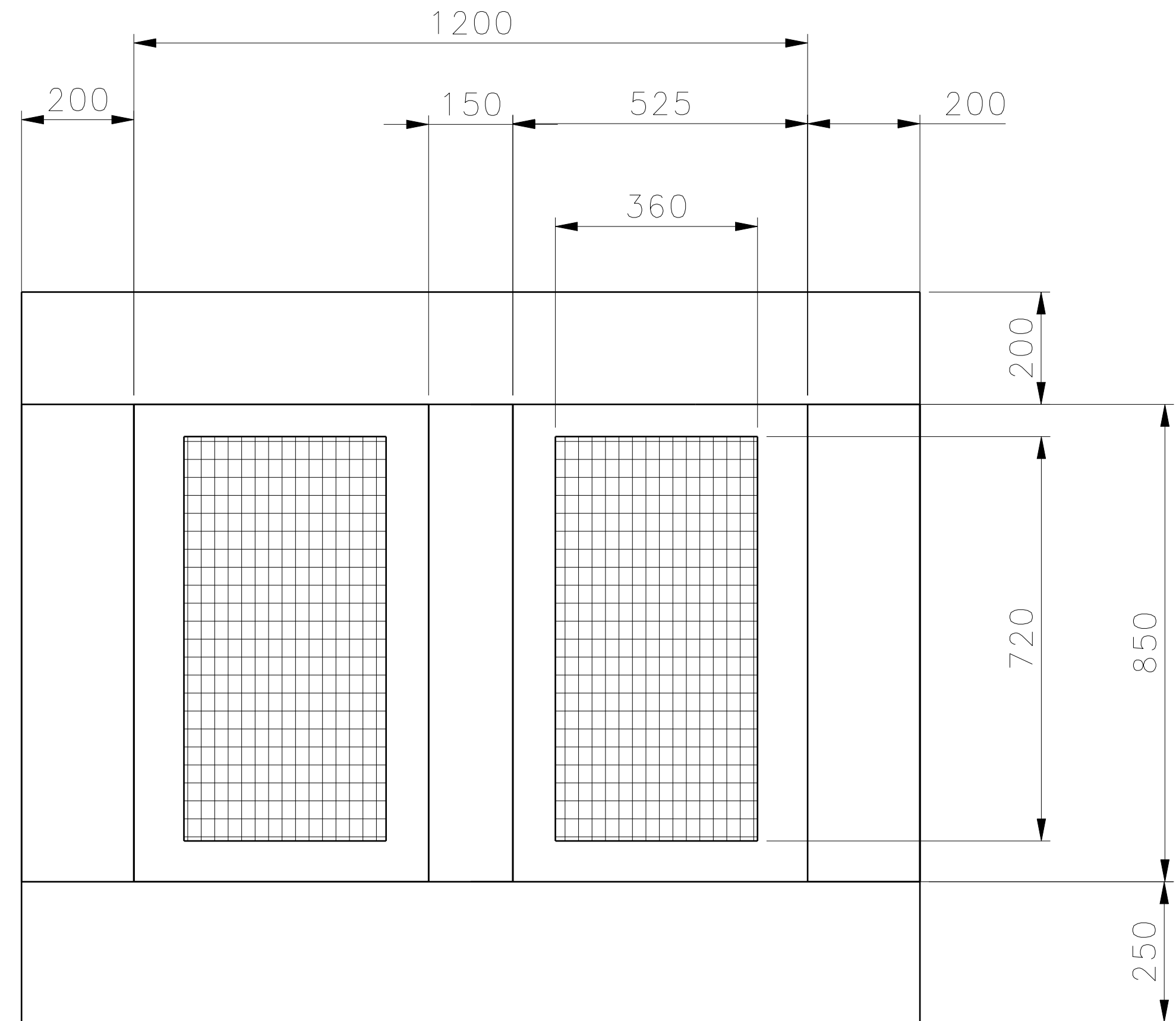

Top view
Scale: 1:8

NOTES:

CONNECTIONS		
A	COMPRESSED AIR OUTLET	1 1/4" MALE
B	ELECTRICAL ENTRY	58.5
C	OIL TANK DRAIN	3/4 FEMALE WITH PLUG
D	AIR COOLING FLOW RATE	11 m ³ /min
E	CONDANSATE DRAIN POINT	—
F	WEIGHT	940

25.05.2020

ITEM NO.	QTY	REGD	CODE IDENT	PART OR IDENTIFYING NO	NOMENCLATURE OR DESCRIPTION	MATERIAL	SPECIFICATION	ZONE
LIST OF MATERIALS OR PARTS LIST								
THIS DRAWING IS THE PROPERTY OF ANKARA HAMAK IND. AND IS TRANSMITTED IN CONFIDENCE. NEITHER RECEIPT NOR POSSESSION CONFERS OR TRANSFERS ANY RIGHT TO REPRODUCE, USE OR DISCLOSE, IN WHOLE OR PART, DATA CONTAINED HEREIN FOR ANY PURPOSE, WITHOUT THE WRITTEN PERMISSION OF ANKARA HAMAK IND.								
UNLESS OTHERWISE SPECIFIED DIMENSIONS ARE IN INCHES TOLERANCES ON				CONTRACT NUMBER				
FRACTIONS				DATE OF DRAWING				
DECIMALS				DRAFTSMAN				
± .X ± .5				CHECKER				
ANGELS				M. SİMSEK				
± .XX ± .25				ENGINEER				
± .XXX ±				I. ÜRKÜT				
VORTEX COMPRESSOR				MANUFACTURING		WELDING		CODE IDENT NO.
NEXT ASSY				USED ON		APPROVED		R. ÖKÇÜN
APPLICATION				SCALE		UNIT WT		LB SHEET OF

VSD 55 COMPRESSOR
DIMENSIONS

CODE IDENT NO.
A0
DRAWING NO.
10-0550-8010